

WIRING OF MCD3 THERMOSTAT

Heating load less than 3600W

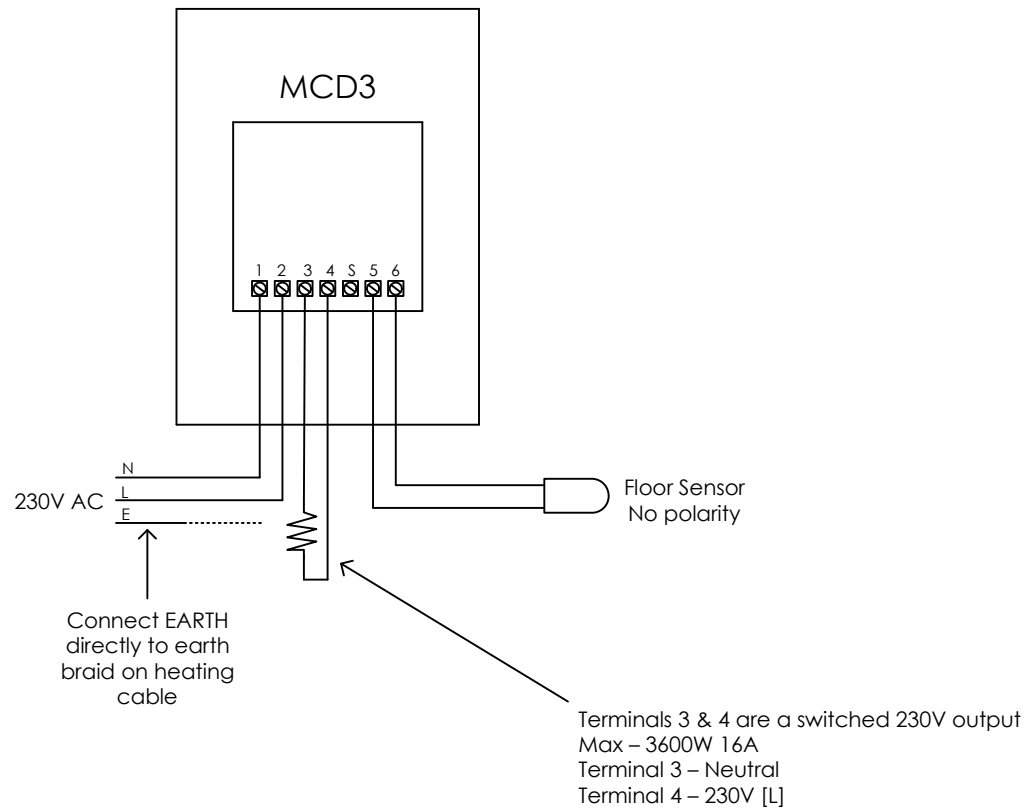

NOTE: Earth screen of all heating cables is to be connected to EARTH

WIRING OF MCD3 THERMOSTAT AND CONTACTOR

Where the floor heating load exceeds 3400W a contactor needs to be installed

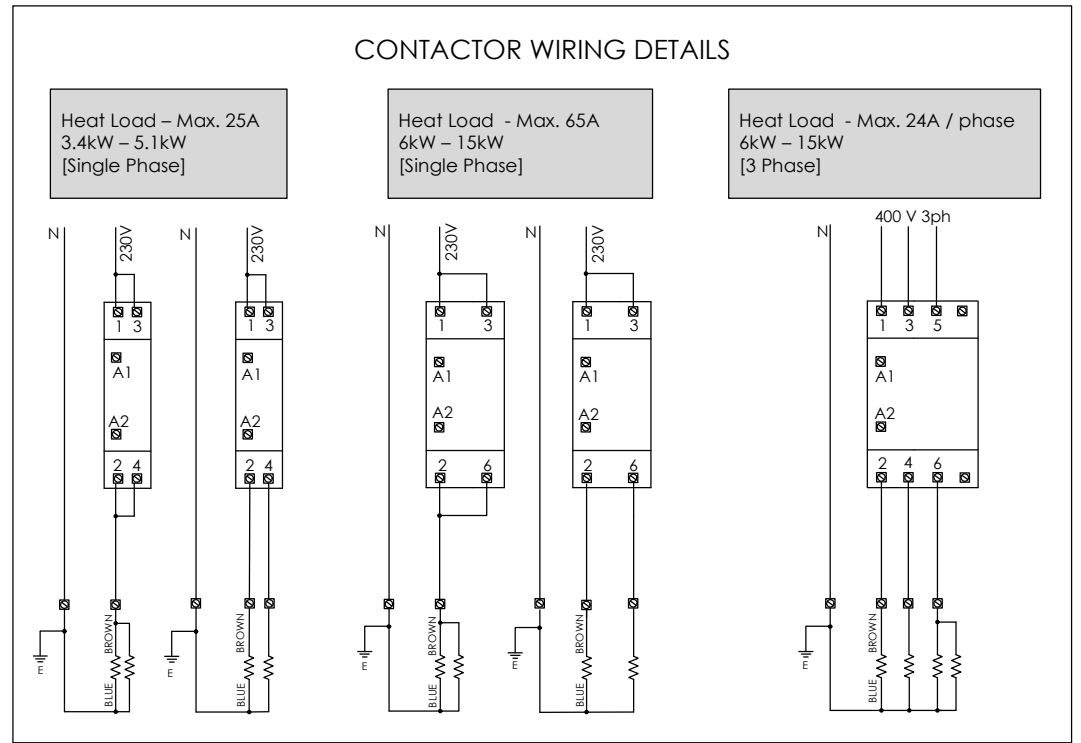
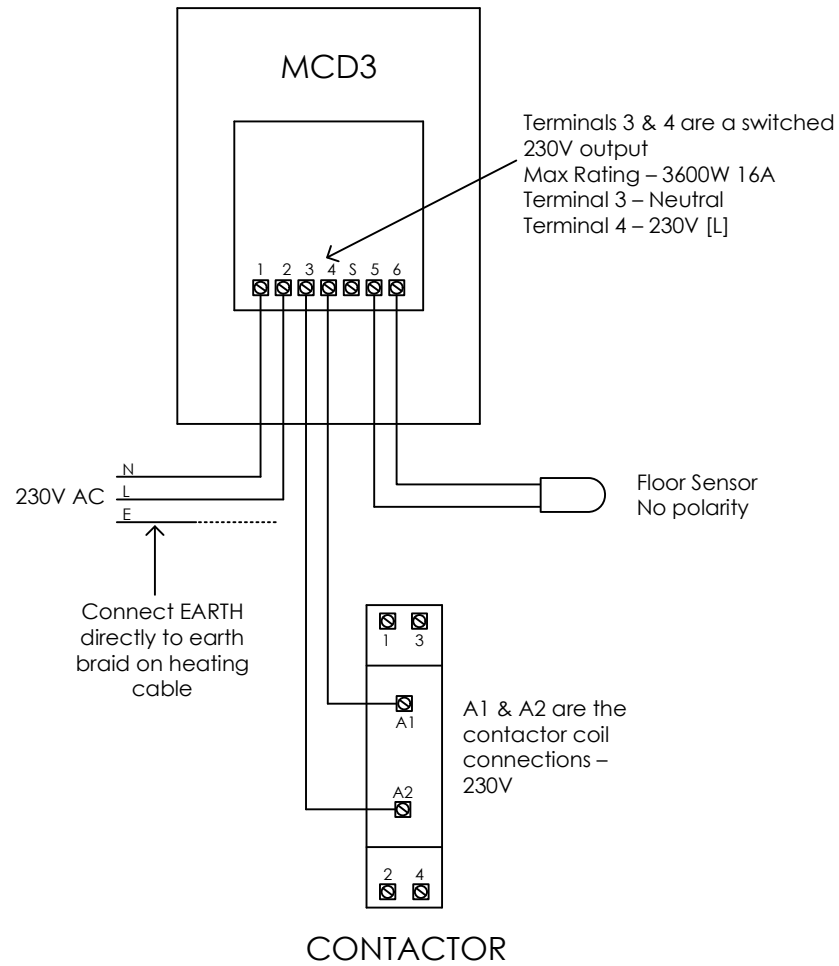

NOTE: Earth screen of all heating cables is to be connected to EARTH