



Step By Step Guide to Installing Your Ultra-Thin Large Area Kit

Before installation - check the following

1. The floor area is clean of dirt and dust.
2. Two conduits should be installed inside the wall cavity before you lay mats, for your sensor and heating cable.
3. In your kit you will find a 'resistance card'. Check your resistance and compare with the factory reading. Resistance should be between -5% to +10% of the value noted on the factory resistance check.
4. When heating multiple rooms, always compare back to your supplied 'Comfort Heat Design Layout', that you are installing the mat allocated to that room.
5. Before laying mats you need to chase into the floor so that the sensor tube and cold tails sit flush with the floor level. Refer to 'Design Layout' and 'Sensor Tube Assembly Page'.

Important Notes

1. The tile adhesive needs to cure. You need to wait at least 3 weeks before turning on your floor heating. When turning on for the first time, increase the floor temperature gradually over 2-3 days.
2. After installation to avoid damage to the cable DO NOT INSTALL YOUR DOOR STOP IN THE FLOOR. You can install door stops in the wall.
3. The final connection of heating cables and thermostat must be carried out by a licensed electrician.
4. NEVER CUT THE HEATING CABLE (grey cable)- Only the cold tail can be shortened (black/blue cable).
5. The heating cable should never touch or cross over. All heating mats are spaced 100mm apart unless otherwise advised on your 'Design Layout'.
6. Generally, the thermostat set at 24-25 deg C will result in a comfortable floor temperature.



Step By Step Guide to Installing Your Ultra-Thin Large Area Kit

Technical Data

Cable Type:	Twin conductor heating cable with earth screen.
Construction:	Multi-strand heating wire wound around kevlar core with double insulation, earth screen & sheath.
Insulation Rating:	4000 V
Rated Voltage:	240 Volts AC
Rated Output:	17W/m
Cold Tail Length:	2.5 metre with invisible splice connection
Cable Diameter:	6.9 mm
Cable Standard:	IEC800 Class II

Installation

1. Before laying mats you must chase the floor to allow the floor sensor and cold tails to sit flush with floor level.
2. The floor should be treated with a primer. This will allow the tile adhesive to stick to the sub-floor.
3. Slide sensor tube into the conduit and install sensor, using supplied lubricant. Refer to "Sensor Tube Assembly" page. Glue sensor tube into your chased groove.
4. Lay mat according to 'Design Layout' supplied. Starting at thermostat location, lay mats until you cover the required area, always remaining 100mm of walls and fixtures. Mats are either glued, clipped or taped to the floor. The cold tails can then be pushed up the conduit.
5. Check the resistance of the cable and compare with 'resistance card' supplied.
6. The floor is now ready to tile. It is recommended that you use a thin 'Ardit' before your tile adhesive. This makes installation easier, or you can screed over the area with a thin layer of your tile adhesive before tiling.
7. You will need to supply your electrician with the nominated loads for each room.

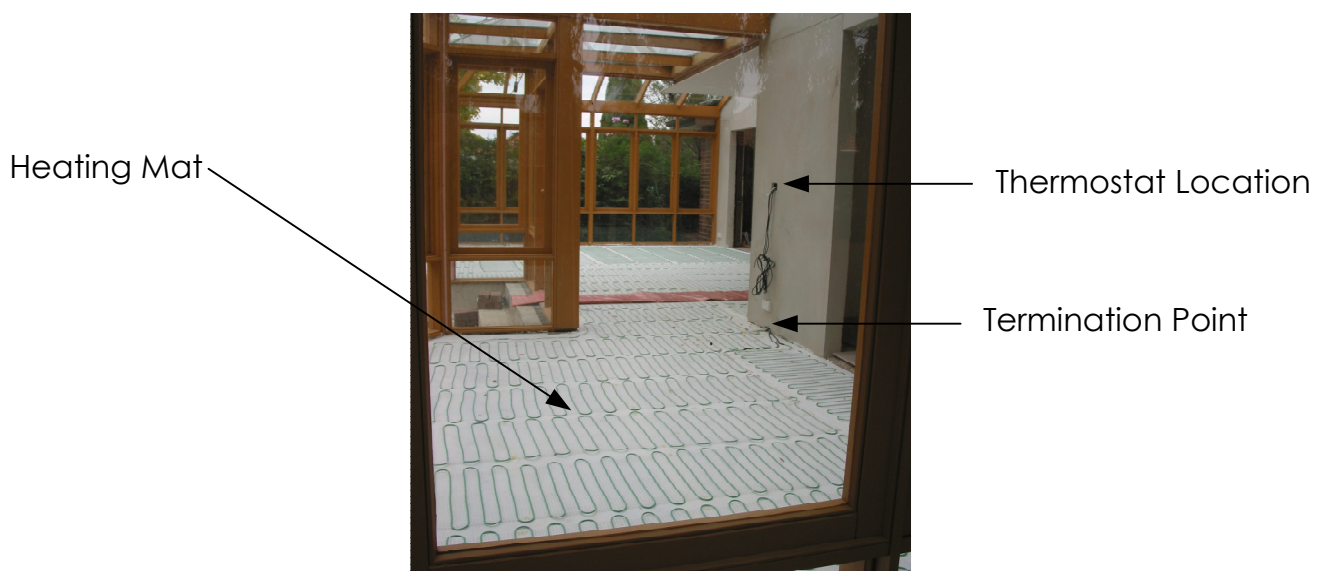



Mat Installation Guide - Ultra-Thin

How To Cut Mat

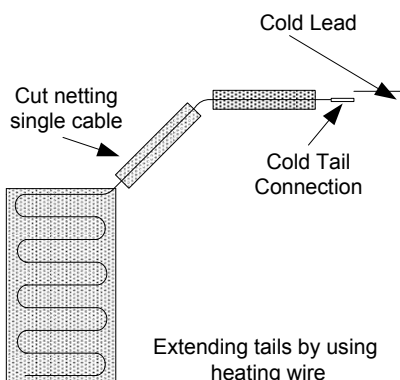
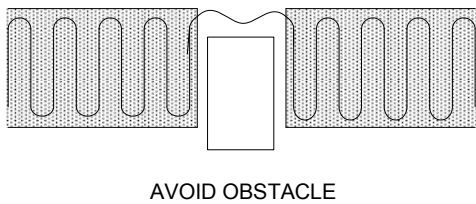
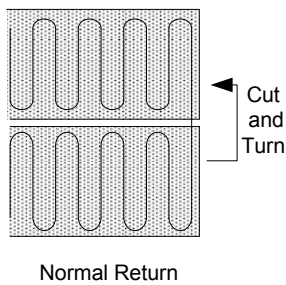
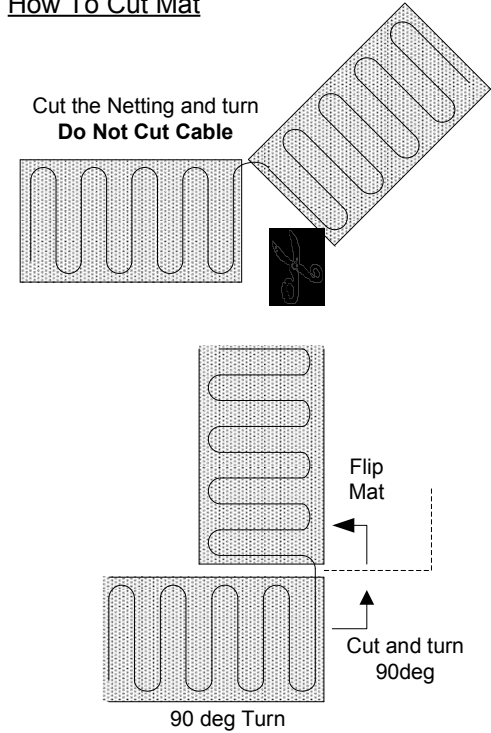

Typical PV3L & PVS Mat Dimensioning

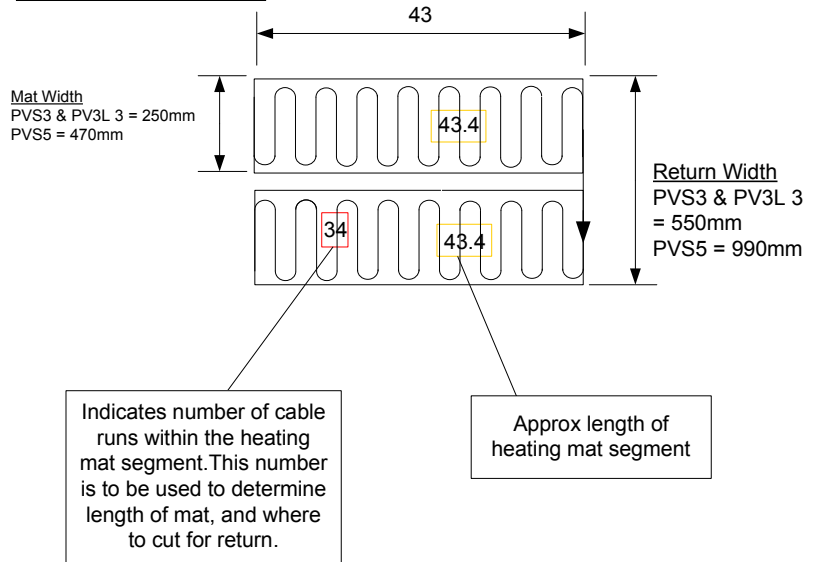

- NEVER CUT THE HEATING CABLE
- NEVER OVERLAP OR CROSS THE HEATING CABLE

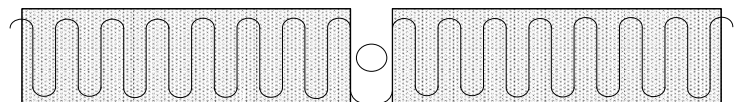
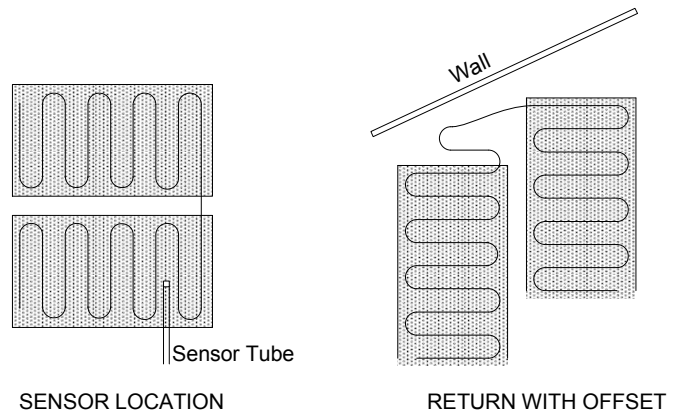

HEATING MAT INSTALLATION AROUND FLOOR WASTE



Sensor Tube Assembly for Ultra-Thin Mats

The sensor tube assembly allows for easy installation & removal of the thermostat sensor. Should the sensor fail or the thermostat needs replacing, the sensor tube will allow for the sensor to be replaced.

LENGTH - 2.5m Outside Dia - 12mm

Location

The sensor end should be located in the floor between the heating cables so that the thermostat sensor will measure the average temperature. The sensor tube should not pass over or under the heating cable.

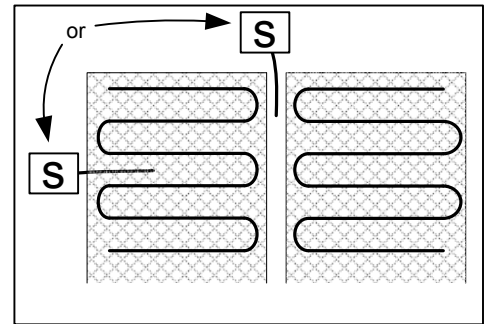

Tube Installation

The sensor tube is installed inside conduit. Ensure all bends are large and smooth, to ensure the sensor will easily slide down the tube. The capped tip of the sensor tube should be suitably located to allow the sensor to measure the average floor temperature. Secure the sensor tube in place and any excess tube at the bracket mounting can be trimmed back. If electrical conduits can not be installed in the wall, a draw wire can be used to pull the sensor tube up the wall cavity.

CABLES - Between adjacent cables and min 150mm in from end.

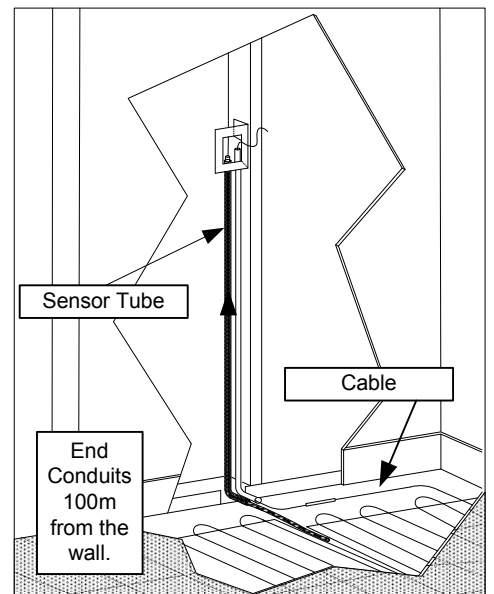

Sensor Installation

Prior to installing the thermostat sensor, apply 2-3 drops of lubricant inside the sensor tube. Slide the sensor down the tube until reaches the sensors capped tip.

Tip

To ensure the sensor tip does not move away from the end of the tube, wrap tape around the top of the sensor tube.

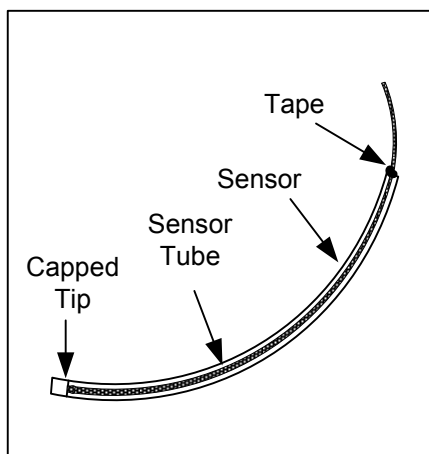

Ultra-Thin

In Ultra-Thin heating applications the floor needs to be chased to allow the sensor tube to be recessed. Once in place, the sensor tube is glued down.

