



Step By Step Guide to Installing Your In-Screed Bathroom Kit

Before installation - check the following

1. The floor area is clean of dirt and dust.
2. If you have waterproofed your floor before screeding, make sure the membrane has not been damaged. (you can also waterproof above your screed)
3. Two conduits should be installed in the wall cavity before you lay cable for your sensor and heating cable.
4. In your kit you will find a 'resistance card'. Check your resistance and compare with the factory reading. Resistance should be between -5% to +10% of the value noted on the factory resistance check.
5. When heating multiple rooms, always compare back to your supplied 'Comfort Heat Design Layout', that you are installing the correct cable allocated for the room.

Important Notes

1. The sand and cement screed needs to cure. You need to wait at least 3 weeks before turning on your floor heating. When turning on for the first time, increase the floor temperature gradually over 2-3 days.
2. After installation to avoid damage to the cable DO NOT INSTALL YOUR DOOR STOP IN THE FLOOR. You can install door stops in the wall.
3. The final connection of heating cables and thermostat must be carried out by a licensed electrician.
4. NEVER CUT THE HEATING CABLE (yellow cable)- Only the cold tail can be shortened (black cable).
5. The heating cable should never touch or cross over. Heating cables are spaced at 100mm apart unless you are otherwise advised on your 'Design Layout'. For small areas you will be advised to space the cable at 75mm.
6. Generally, the thermostat set at 24-25 deg C will result in a comfortable floor temperature.



Step By Step Guide to Installing Your In-Screed Bathroom Kit

Technical Data

Cable Type:	Twin conductor heating cable with earth screen.
Construction:	Multi-strand heating wire wound around kevlar core with double insulation, earth screen & sheath.
Insulation Rating:	4000 V
Rated Voltage:	240 Volts AC
Rated Output:	17W/m
Cold Tail Length:	2.5 metre with invisible splice connection
Cable Diameter:	6.9 mm
Cable Standard:	IEC800 Class II

Installation

1. Measure room and lay mesh accordingly, 100mm off walls and amenities. You can connect the mesh strips together by using supplied pliers and clips.
2. Starting at thermostat location, begin connecting cable to mesh with pliers and clips. The cable should be either connected to every second run of mesh (100mm spacing), or every one½ (75mm spacing). Always refer to supplied "Design Layout".
3. Install sensor tube into one of the conduits and slide in sensor, using supplied lubricant. Refer to "Sensor Tube Assembly" page.
4. Check the resistance of the cable and compare with 'resistance card' supplied.
5. The floor is now ready to screed.
6. You will need to supply your electrician with the nominated loads for each room.

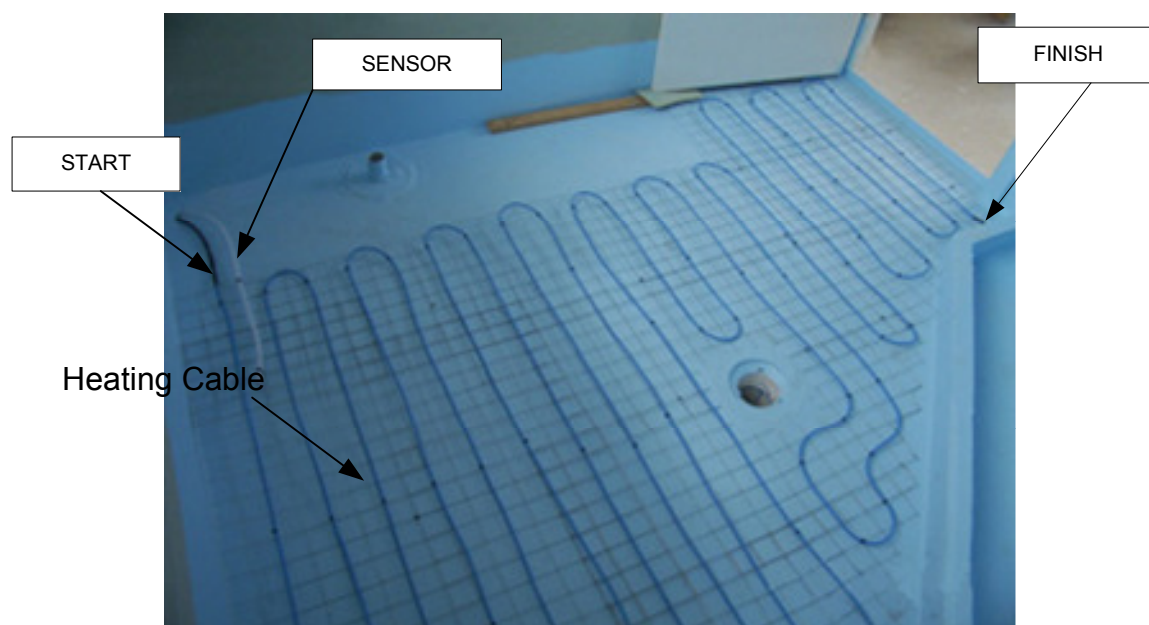



Cable Installation Guide

In-Screed 'Twin' Heating Cable – On Mesh

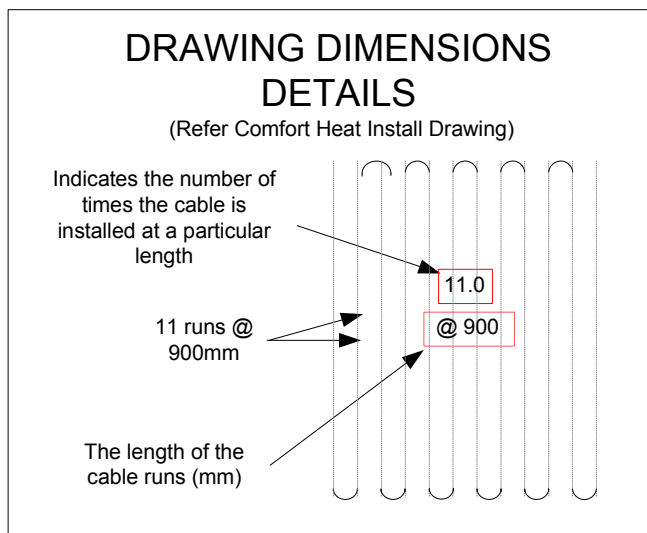
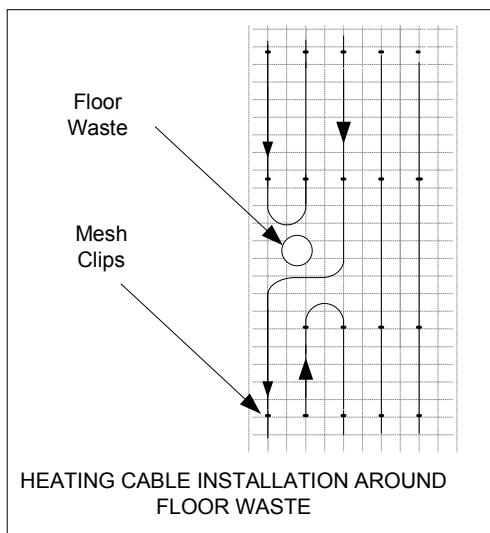
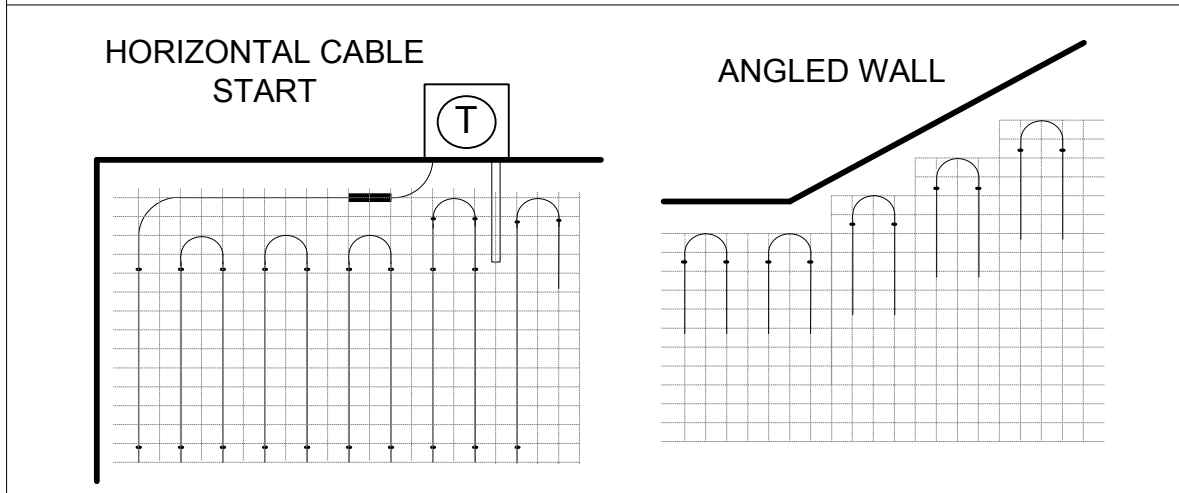
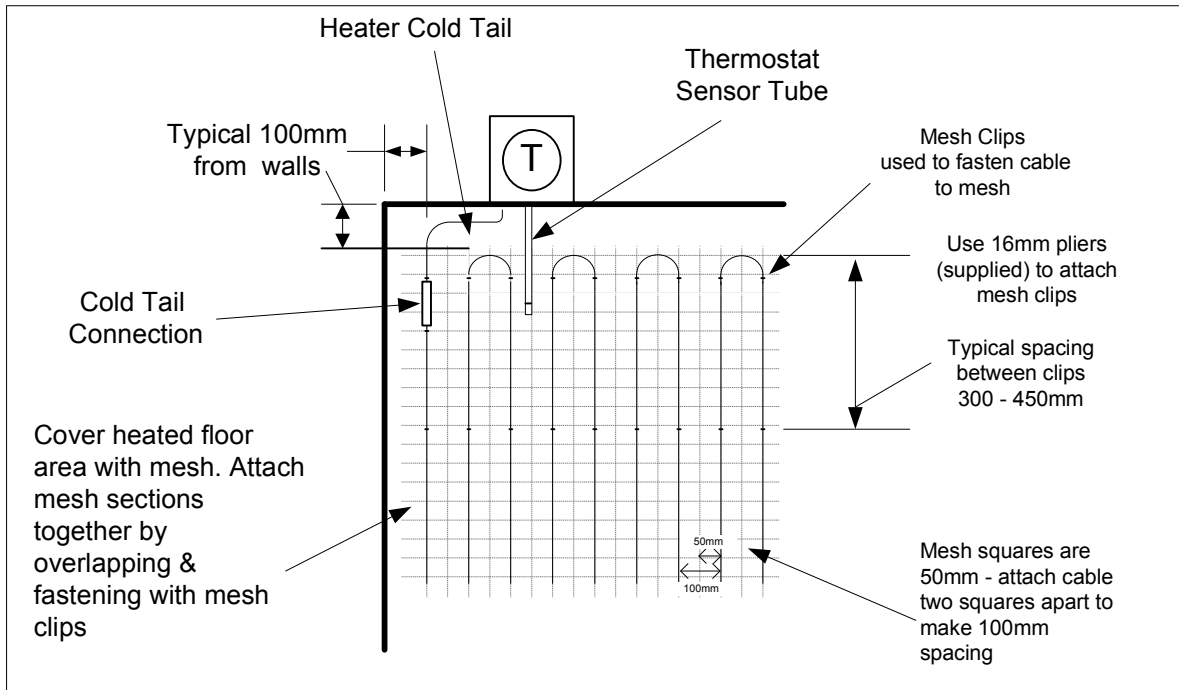



Sensor Tube Assembly for In-Screed

The sensor tube assembly allows for easy installation & removal of the thermostat sensor. Should the sensor fail or the thermostat needs replacing, the sensor tube will allow for the sensor to be replaced.

LENGTH - 2.5m Outside Dia - 12mm

Location

The sensor end should be located in the floor between the heating cables so that the thermostat sensor will measure a typical floor temperature.

Wherever possible the sensor tube should not pass over or under the heating cable.

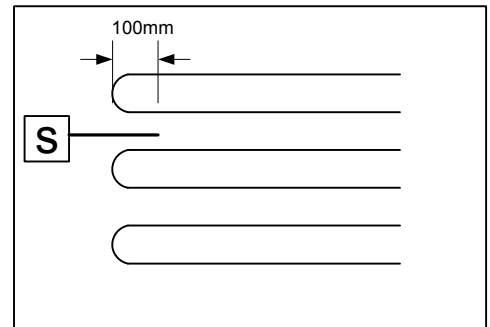

CABLES - Between adjacent cables and min 150mm in from end.

Tube Installation

The sensor tube is installed in the conduit. Ensure all bends are large and smooth, so the sensor will easily slide down the tube. The capped tip of the sensor tube should be suitably located to allow the sensor to measure the average floor temperature. Secure the sensor tube in place on the mesh with cable ties and any excess tube at the bracket mounting can be trimmed back.

If electrical conduits can not be installed in the wall, a draw wire can be used to pull the sensor tube up the wall cavity.

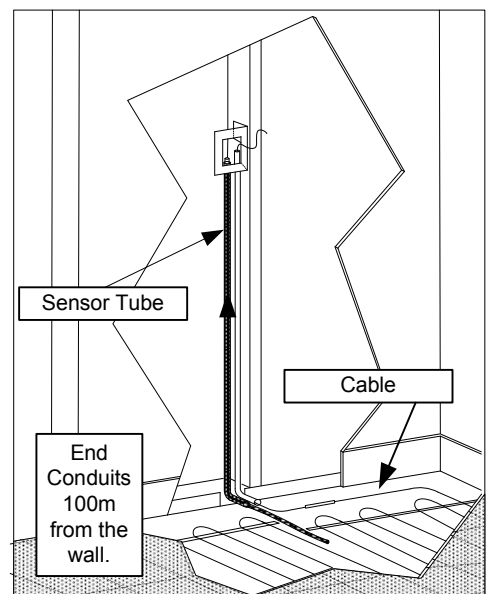

Sensor Installation

Prior to installing the thermostat sensor apply, 2-3 drops of lubricant inside the sensor tube. Slide the sensor down the tube until it reaches the sensors capped tip.

Tip

To ensure the sensor tip does not move away from the end of the tube, once in place, wrap some tape around the top of the tube.

