



## MCC2/MCD2 operations manual

A Comfort Heat floor heating system has been installed in your floor. Under floor heating will warm from the floor up giving you unparalleled feeling of comfort. This heating system is controlled by an electronic thermostat that has a floor or air sensor for optimum temperature control.

### PROIR TO TURNING ON

The sub-floor and screed have to be fully cured before turning the heating on. For sand & cement screeds you must wait at least 3 weeks before turning on. With Ultra-thin installations, you must wait 2-3 days for the tile glue to cure. When turning on the floor for the first time, increase the floor temperature gradually over 2-3 days.

#### WARRANTY

TILE - 10 years  
CARPET - 5 years  
TIMBER - 5 years  
SLAB - 10 years  
THERMOSTAT & SENSOR - 2 years

#### TEMPERATURE SETTINGS

TILE: 24 -26°C max. temp 30 deg °C  
CARPET: 25°C max. temp 28°C  
TIMBER: max. temp 27°C  
SLAB: max. temp 27°C  
THERMOSTAT & SENSOR: 2 years

The MICROTEMP RANGE of electronic thermostats are specifically designed for underfloor heating systems. The thermostats are vertically flush mounted and have a 2pole isolator with 16A output relay.

**MCC2** - The MCC2 thermostat has a built in programmable time-clock to automatically turn the floor heating system ON and OFF at selected times. During the OFF periods the floor does not turn OFF but programs the floor temperature to your selected 'set back temperature'. When the ∩∩∩ appears on your screen, the floor is heating. If you see 'E1' or 'E2' there is an error.

**MCD2** - The MCD2 thermostat contains all the programmable functions of the MCC2 with the addition of an air sensing option with floor limit mode or floor sensor only. We recommend that all electric floor heating installations operate in floor sensing mode and hydronic installations operate in air sensing with floor limit mode for optimal comfort.



MCC/MCD2

#### TECHNICAL DATA

Supply Voltage:	240Vac, 50/60hz
Output Relay:	16A SPST, 3600W max
Switching Differential:	0.4 degC
Built-in Switch:	2 pole 16A
Temperature Range:	0/+50 degC
Housing/protection:	IP20 & IP21
Dimensions (HxWxD):	115mm x 84mm x 58mm
Sensor Length:	3m
Warranty:	2 years
Mounted:	Vertically/Flush Mounted



## BASIC SET UP

Set the date and time when the thermostat is turned on for the first time or reset.

>Press on/off button to turn thermostat on - (display will flash)

>Press up and down arrow keys to set the correct time

>Press tick button once you have the correct time displaying

Next, set the day of the week;

>Press up and down arrow keys to set the day of the week (1-7 at the bottom of the display) (1=Monday - 7=Sunday)

>Press tick button once you have the correct day displaying

The thermostat is now set to 'factory default' settings and is fully operational.

Default setting for MCC2 - floor sensing

Default setting for MCD2 - air sensing

If your thermostat has already been set up but you are not sure if the settings are correct, you can reset your thermostat by pressing a pin into the reset hole for 3 seconds. You will need to then set the time and day as listed above.

Default settings:

weekdays (day 1-5): on at 6am - 25°C  
off (set back) at 8am - 20°C  
on at 4pm - 27°C  
off (set back) at 10.30pm - 20°C

note: thermostat does not "turn off" but changes to a "set back" temperature. This set back temperature can be changed.

week - ends (day 6-7): on at 8am - 27°C  
off (set back) at 11pm - 20°C

## MANUAL MODE SETUP

Temporary override of the automatic on /off programmed setting.

>Press the tick button once - hand will display.

>Press up and down arrow keys to set the desired floor temperature

The display will flash on the screen and then stop automatically.

Thermostat is now in manual mode.

To change the thermostat back to automatic mode - press the tick button again

## PROGRAMMABLE MODE SETUP

Please refer to our full thermostat manual to program customised settings.

## MCD2 ONLY - AIR WITH FLOOR LIMIT / FLOOR ONLY / AIR ONLY MODE SETUP

Select between sensing modes

>Hold the 'Up' & 'Down' buttons together for approx 3 seconds until 'Info' is displayed.

>Press the 'Down' button until 'APP' is displayed and press the 'Tick' button.

roLi = Air Sensor with Floor Limit Flo= Floor Sensor Only ro=Air Sensor Only

>Press the 'Down' button to change to your selected sensing mode and press 'Tick' button

You can now select the temperate settings and press the 'Tick' button to confirm

---

## CONNECTING MCC2/MCD2 TO SMART POWER METER

The Smart Power Meter varies the power tariff rate at different times of the day. Overnight the rate is at 'Off Peak' rates and during the afternoon and evenings there is the 'Peak' rate. At the times between these there are 'Shoulder' rates. The exact times of these rates should be confirmed from your power provider.

As the cost of electricity during 'Peak' times is more expensive than during the 'Off Peak' or 'Shoulder' times the MCC2 thermostat should be programmed to 'TURN OFF' when it is 'Peak' periods. Following is an outline on how to achieve this arrangement:-

1. Set the Adaptive Function to 'Off' – The adaptive function is a program within the thermostat that tries to predict when the floor heating should be turned on to achieve the selected temperature at the 'Time On' setting. As this may allow the floor heat to operate during the 'Peak' period. Check this function is 'Off' in the thermostat program as follows:-

>Hold the 'Up' & 'Down' buttons together for approx 3 seconds until 'Info' is displayed.

>Press the 'Up' button until the 'AdAP' is displayed and press the 'Tick' button.

>Press the 'Down' button to change 'On' to 'Off' and press 'Tick' button

>Press the 'Down' button to display 'End' and press 'Tick' button.

2. Programme the daily 'off' event to coincide with the 'Peak' times

# INSTRUCTIONS

## Type MCC2-1991/MCD2-1991

### Product program

This user manual covers following electronic thermostats  
 MCC2-1991-CO. Incl. floor sensor 3m  
 MCC2-1999-CO. With built-in room sensor  
 MCD2-1999-CO. With 2 sensors; built-in room sensor and incl. floor sensor 3m

### Introduction

The thermostat is capable of switching on your heating system at pre determined times on different days of the week. It is possible to set 4 periods called events each day with different temperatures. From factory a default schedule is programmed suitable for most installations. Unless you change these settings the thermostat will operate to this default program.

Working with lower temperatures during times that the room is unoccupied will lower your energy costs without reducing the comfort. The thermostat has an adaptive function that automatically changes the start time of a heating period so that the desired temperature is reached at the time that you set. After 3 days the adaptive function has learned when the heating must be switched on.

**Type MCC2-1991-CO** has an external temperature sensor that is normally placed in the floor construction. In this configuration the thermostat controls the temperature of the floor and not the temperature within the room.

**Type MCC2-1999-CO** has a built-in temperature sensor. In this configuration the thermostat controls the temperature of the room.

**Type MCD2-1999-CO** has a built-in temperature sensor and an external temperature sensor. In this configuration the thermostat controls the temperature within the room and use the external temperature sensor as limit sensor avoiding to high or to low temperatures in the floor construction.

The thermostat has a pin button marked R, allowing you to reset the thermostat to factory settings. These are listed at the end of this manual with space for you to record your own weekly schedule.

The display is backlit when operating the buttons. The heating element is switched off when the light is on in the display

The heating system can be switched off on the built-in interrupter. The Microprocessor taking care of the time will still be supplied with power whereby time and day will be maintained. When the heating is required and the thermostat is switched on, it will continue the 4-event program based on present time and day.

### 1. Getting started

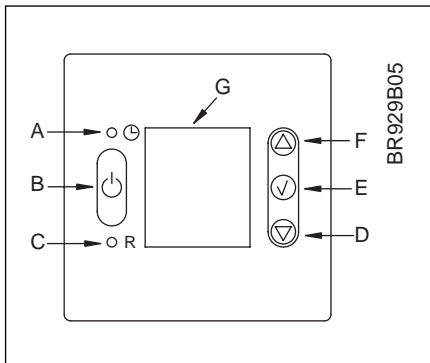

A:	B:	C:	D:
Pin button adjust of clock	On/off	Reset to factory setting	Adjustment down

E:	F:	G:
OK - accept	Adjustment up	Display

### Display symbols

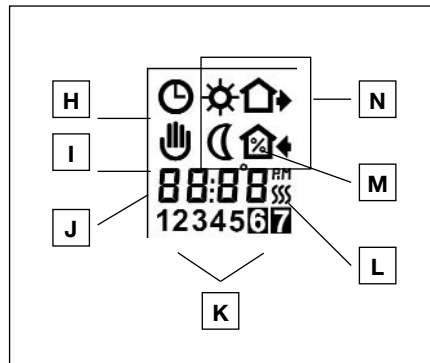

H:	I:	J:	K:
Clock function	Manual mode	Time and temperature	Day number

L:	M:	N:
Heating on	% Monitoring of switch-on time	4-event symbol Out Night Home

### Setting the thermostat into operation

First time power is connected the clock and day will be flashing and must be set. If you need to adjust the time of the thermostat at a later date, insert a pin into the hole for setting of time and day. Adjustment must be made for summer and winter time.

		Press the UP () or DOWN () buttons to select the correct time and press OK button () button.	
		Then press the UP () or DOWN () button to select the correct day and press OK () button.	1-7

## 2. Daily use of the thermostat

### 4-event clock mode

The day has been split into 4 events describing a typical day. When the thermostat is in 4-event mode it will automatically adjust the temperature according to the required temperature to the required time. As standard the thermostat has 5 days with 4 events, and 2 days with 2 events. Programming see 3.

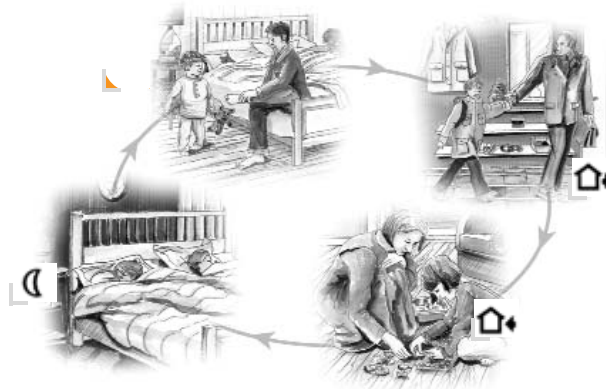

<b>4-event clock mode:</b>		The clock function symbol (⌚) and one of the 4-event symbols (🏠, 🍴, 🛏, 🌙) will be indicated. Programming see 3.
		<b>Temporary override</b> To temporarily override the temperature in the 4-event schedule program, press the UP (▲) or DOWN (▼) button once, to show the temperature, and press again to increase or decrease the temperature. The display will flash for 5 seconds, and will then revert to the time. The override will operate until the next programmed event when the unit will resume the automatic program.
		<b>Cancel comfort mode</b> To cancel the override state, press the OK (✓) button twice.
<b>Manual mode:</b>		<b>Permanent override:</b> During holidays, the scheduled 4-event program can be overridden. Press the OK (✓) button, and then the UP (▲) or DOWN (▼) button until the override temperature is set. The unit will now operate to this temperature permanently.
		<b>Cancel manual mode</b> To cancel the permanent override state press the OK (✓) button once, and the unit will resume automatic function.

## 3. Programming

### 4-event time and temperature

For each event, the start time and required temperature must be set.

For example, in the morning you wish the heating to start at 07:00 and the temperature to rise to 25°C. Press OK (✓) button for 3 seconds and the start time is displayed. Change this to 07:00 with the UP (▲) or DOWN (▼) button. Press OK (✓) to confirm.









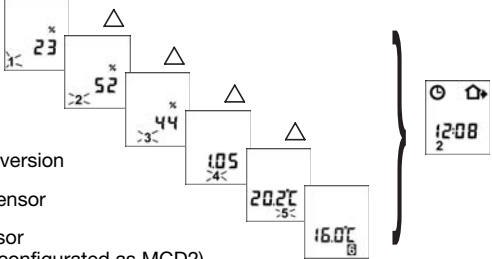

The temperature is now displayed. Change this to 25°C with the UP (▲) or DOWN (▼) button. Press OK (✓) button to confirm. This action can now be repeated for the second event.

These settings will be valid with days 1-5 showing on the display. To program the days 6 and 7, repeat the above. Days 6 and 7 are usually Saturday and Sunday, and only have two events.

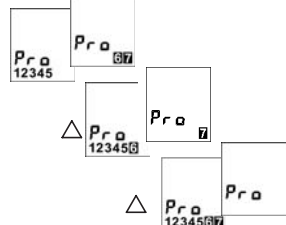

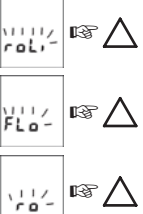
The temperature can be set within the range of +5 to +40°C. It is also possible to select the heating OFF at that event by reducing the setting to 5°C, and then pressing the (▼) once more.

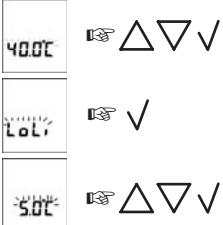
Press OK (✓) button for 3 secs. to begin programming		
<b>Day 1 - 5</b>		
<b>Day 6 - 7</b>		

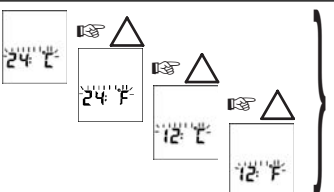
#### 4. Advanced settings and read-out

	<p>Press both UP (Δ) and DOWN (∇) buttons together for 3 seconds. INFO is displayed. Press UP(Δ) button until you reach the desired sub menu. Select the sub menu with the OK (✓) button.</p>
	<p><b>Monitoring of energy consumption</b> The thermostat calculates average time it has been switched on allowing you to monitor your energy consumption. In the thermostat you can read out: Total switch-on time in percentage in the latest 2 days, 30 days or 365 days. <b>Calculation of operational costs per day:</b> (switch-on time:100) x kW x kWh-price x 24 h per day <b>Example:</b> Read-out: 30 % in the latest 365 days Size of heating system: 1.2 kW (ask the installer) Cost of power: 0.2 AUD / kWh Calculation: (30:100) x 1.2 kW x 0.2 AUD / kWh x 24 h = 1.7 AUD per day</p>
	<div style="display: flex; align-items: center;"> <div style="margin-right: 20px;"> <p>2 days</p> <p>30 days</p> <p>365 days</p> <p>Software version</p> <p>Control sensor</p> <p>Limit sensor (visible if configured as MCD2)</p> </div>  <div style="margin-left: 20px;"> <p>Press UP (Δ) or DOWN (∇) button to show the different readouts.</p> <p>No changes can be made here. Use the OK (✓) button to end.</p> </div> </div>
	<p><b>4-event sequence</b> The present event sequence flashes: Days 1-5, followed by days 6-7. To change, press the UP (Δ) button until you have days 1-6 and then day 7 flashing, or all 7 days are flashing. Select the required sequence with the OK (✓) button.</p>
	<div style="display: flex; align-items: center;"> <div style="margin-right: 20px;">  </div> <div style="margin-left: 20px;"> <p>5-2: 4 events in 5 days + 2 events in 2 days.</p> <p>6-1: 4 events in 6 days + 2 events in 1 day</p> <p>7-0: 4 events in 7 days</p> </div> </div>
	<p><b>Selection of type (only visible in type MCD2)</b> Type MCD2-1999-CO has a built-in temperature sensor and an externally temperature sensor. In this configuration the thermostat controls the temperature within the room and use the externally temperature sensor as limit sensor Type MCD2 can be changed into type MCC2-1991-CO with an external temperature sensor that normally is placed in the floor construction. In this configuration the thermostat controls the temperature of the floor and not the temperature within the room. MCD2 can also be changed into type MCC2-1999-CO with a built-in temperature sensor. In this configuration the thermostat controls the temperature of the room, and the external temperature sensor should not be installed.</p>
	<div style="display: flex; align-items: center;"> <div style="margin-right: 20px;">  </div> <div style="margin-left: 20px;"> <p>MCD2-1999-CO With 2 sensors; built-in room sensor and incl. floor sensor 3m</p> <p>MCC2-1991-CO Incl. floor sensor 3m</p> <p>MCC2-1999-CO With built-in room sensor</p> </div> </div>
	<p><b>Max and min allowed temperature range</b> The temperature setting range of +5° to 40° C can be limited to prevent a too high or too low temperature being selected under manual or comfort mode. For MCD2 with limit sensor the max and min temperature range refer to the temperature of the limit sensor. For example: A wood floor covering should not be allowed to exceed a maximum of 27°C. Low limitation is used where the temperature of the floor is required never to fall below the minimum set temperature.</p>
	<div style="display: flex; align-items: center;"> <div style="margin-right: 20px;">  </div> <div style="margin-left: 20px;"> <p>Maximum allowed temperature setting. Use the UP (Δ) or DOWN (∇) button to increase or reduce, and OK (✓) button to accept.</p> <p>Next is displayed LoLi. Press OK (✓) button to continue.</p> <p>Minimum allowed temperature setting. Use the UP (Δ) or DOWN (∇) button to increase or reduce and OK (✓) button to accept.</p> </div> </div>
	<p><b>Time and temperature scale selection</b></p>
	<div style="display: flex; align-items: center;"> <div style="margin-right: 20px;">  </div> <div style="margin-left: 20px;"> <p>You can select either °C or °F scale, and 12 or 24 hour clock as follows:</p> <p>Press UP (Δ) or DOWN (∇) button to change settings. Confirm the required scale with the OK button (✓) button.</p> </div> </div>



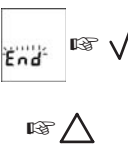

#### 4. Advanced settings and read-out - continued

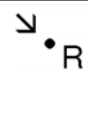
	<p><b>Adaptive function:</b> This function enables the thermostat to calculate when it needs to switch ON so that the required temperature is reached at the set time. With a start time of 07:00 therefore, the thermostat may switch ON as early as 06:00 so that the desired temperature of 25°C is achieved by 07:00. Without this function set, the thermostat will start to heat at the time you set.</p>
	<p>Press the DOWN (▽) button to switch between on and off. Press OK (✓) button to confirm.</p>
	<p>Press OK (✓) button to end programming and to return to scheduled programme.</p>

#### 5. Reset to factory setting

	<p>Press the pin button and the thermostat returns to factory settings. Time and day is also reset and must be set according to "Setting the thermostat into operation". <b>Note that a MCD2 that has been modified to a MCC2 (see 4. Advanced settings and read-out, selection of type) will return to a MCD2. Failure code E2 will be displayed if the external sensor has been removed.</b></p>
---	--

#### Factory settings

4-event time and temperature					
Day 1-5	Time	Temperature			
		MCC2-1991	MCC2-1999	MCD2-1999	
	06:00	25°C	20°C	20°C	
	08:00	20°C	15°C	15°C	
	16:00	27°C	22°C	22°C	
	22:30	20°C	15°C	15°C	
Day 6-7					
	08:00	27°C	22°C	22°C	
	23:00	20°C	15°C	15°C	
Hi-Low temp.		OFF/OFF	OFF/OFF	28°C/15°C	
4-event sequence	5:2				
Scale	24 H / °C				
Adaptive control	ON				

#### 6. Failure codes

- E0 = Internal failure, replace thermostat
- E1 = Built-in sensor short-circuit or disconnected, replace thermostat
- E2 = External sensor short-circuit or disconnected



# ComfortHeat

Comfort Heat Australia Pty Ltd  
Unit 8,11 Ponderosa Pde  
WARRIEWOOD NSW 2102  
Phone: (02) 99798600 - Fax: (02) 99797706  
E-mail: [comfortheat@bigpond.com](mailto:comfortheat@bigpond.com)