

WIRING OF MCC2/MCD2/MTC THERMOSTAT AND CONTACTOR

Where the floor heating load exceeds 3400W a contactor needs to be installed

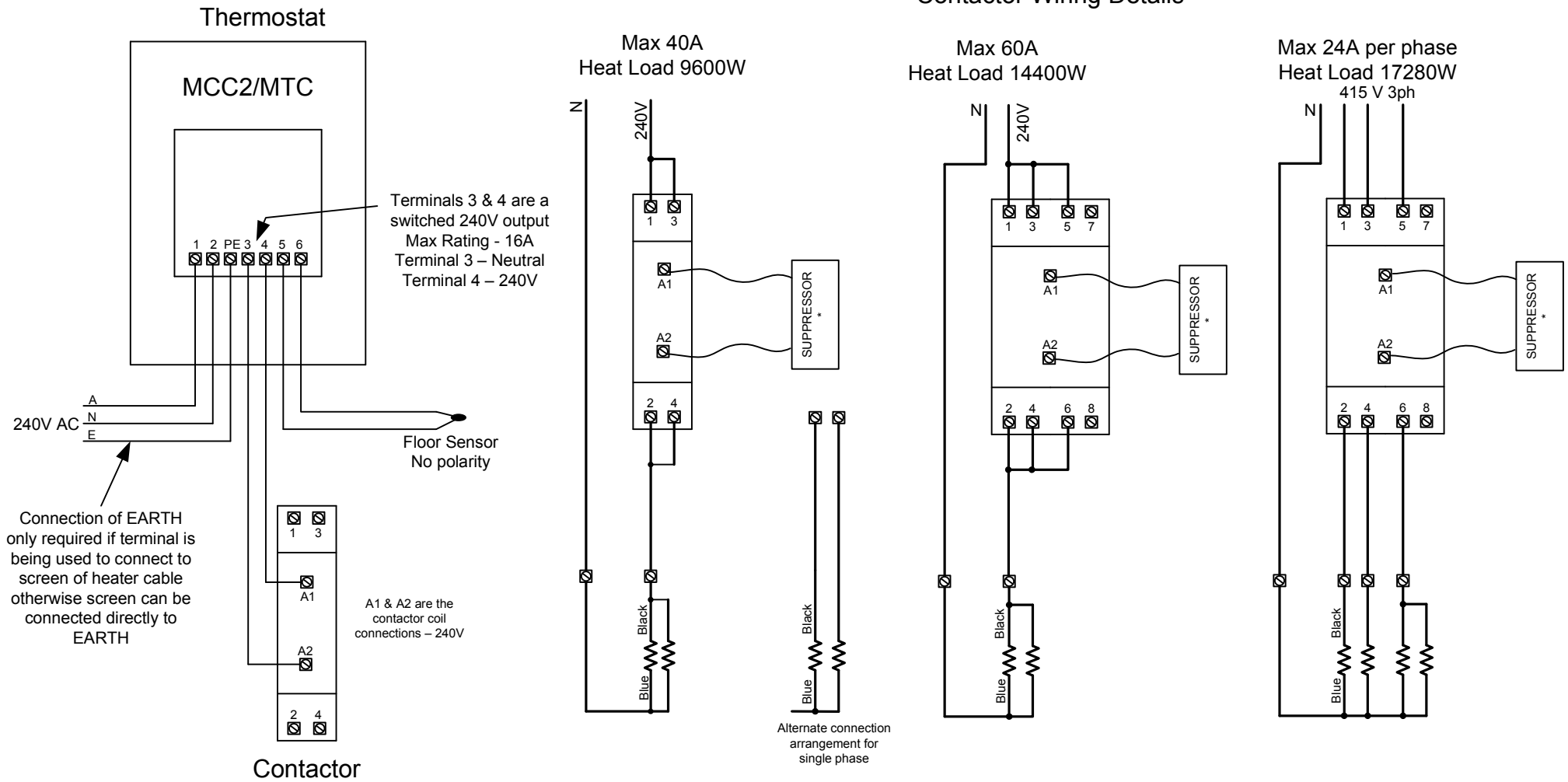

NOTE: Earth screen of all heating cables is to be connected to EARTH

* Suppressors to be fitted across A1 & A2 for all MCC2